

Ambassador

Direct-drive motorized screen with ceiling closure.

The DRAPER AMBASSADOR is a direct-drive, heavy-duty screen designed specifically for recessed installation above any type of ceiling. The AMBASSADOR features a fully automatic ceiling closure, which totally conceals the screen when not in use. The ceiling closure can be finished by the contractor to match the ceiling. Your choice of a conventional viewing surface: fiberglass matt white, glass beaded or HIGH CONTRAST GREY.



System Options

- **Extra Drop**—Up to 12' overall height, either surface color or black. (Surface color is standard).
- **Black Masking Borders**—optional.
- **Control Options**—Refer to page 6.

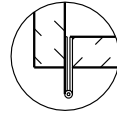
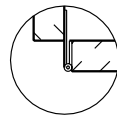
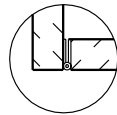

Standard Construction Offset Construction Extended Hinges for Attachment of Ceiling Tile
(Wt. not to exceed 16 oz./sq. ft.)

Dimensions & Data— Ambassador

AV Format Size H x W	Case Length	Net Wt. (lbs.)
50" x 50"	74"	105
60" x 60"	84"	115
70" x 70"	94"	120
84" x 84"	108"	140
72" x 96"	120"	155
96" x 96"	120"	160
7' x 9'	132"	160
9' x 9'	132"	170
8' x 10'	144"	180
10' x 10'	144"	185
9' x 12'	168"	205
12' x 12'	168"	210

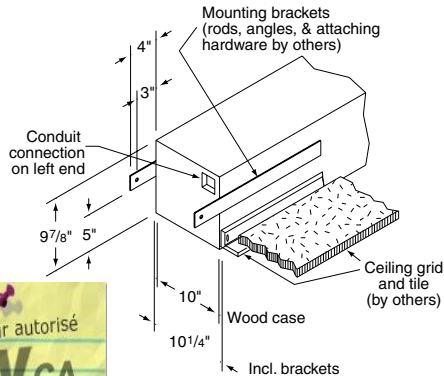

Belden Inc., Richmond, IN. Photographer: Wayne Williams, Indianapolis, IN.

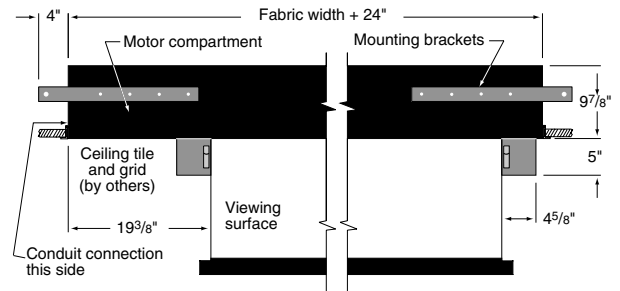

Mounting brackets extend 4" in length beyond ends of case.

