

Premier Series



Tab Tensioning System guarantees perfectly flat surface which delivers exceptional image clarity—for video and data projection.

The PREMIER's automatic TAB TENSIONING SYSTEM delivers perfect picture quality with its perfectly flat viewing surface. Steel case and special tensioning dowel are finished in flat black. The PREMIER's motor is mounted inside the roller on special vibration insulators, so operation is smooth and silent. The PREMIER/SERIES C is manually operated by a slim, polished aluminum crank, which may be detached for storage.

Premier—Motorized screen features DRAPER's TAB TENSIONING SYSTEM, with choice of M1300, M2500 or HiDEF GREY viewing surface. 12" of black drop at top of screen is standard with PREMIER.



Premier/Series C—Manual, crank-operated screen features DRAPER's TAB TENSIONING SYSTEM, with choice of M1300, M2500 or HiDEF GREY viewing surface. 12" of black drop at top of screen is standard with PREMIER/SERIES C.



System Options

- **Extra Drop**—Additional drop optional, either surface color or black. (Black is standard for PREMIER and PREMIER/SERIES C). Additional drop will increase the overall length of the case.
- **Black Masking Borders**—Standard for all formats.
- **Projected Mounting Brackets**—Provide a 6" clearance.
- **Ceiling Opening Trim Kit**—For ceiling-recessed installations. Refer to page 19.
- **Control Options**—Refer to page 6.

Case Dimensions/Method of Installation

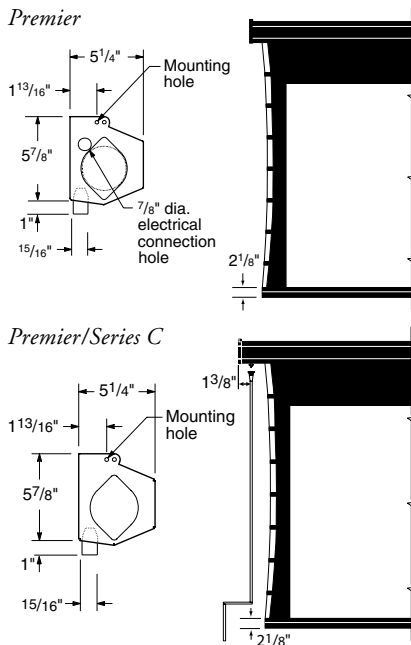

Julian Collaboratory, Julian Science and Mathematics Center, DePauw Univ., Greencastle, IN. Photography: Wayne Williams, Indianapolis, IN.

Dimensions & Data—Premier & Premier/Series C

Size H x W	Case Length*	Dowel Length*	Net Wt. (lbs.)	Size H x W	Case Length*	Dowel Length*	Net Wt. (lbs.)
AV Format							
50" x 50"	68"	60"	30	7' x 9'	128 1/4"	120"	70
60" x 60"	78 3/4"	71"	35	9' x 9'	129 3/4"	122"	75
70" x 70"	89"	82"	40	8' x 10'	141 3/4"	133 1/2"	80
84" x 84"	104 1/4"	96"	50	10' x 10'	143 1/2"	135 3/4"	85
72" x 96"	115"	108"	55	9' x 12'	168 3/4"	158"	90
96" x 96"	117 3/4"	109 1/2"	60	12' x 12'	171 1/2"	161 1/2"	100
Nominal Diagonal	Image Area H x W	Case Length*	Dowel Length*	Net Wt. (lbs.)			
NTSC Video Format (4:3)							
6'	42 1/2" x 56 1/2"	74"	66 1/2"	35			
7'	50" x 66 1/2"	84 1/4"	76 1/2"	40			
100"	60" x 80"	97 3/4"	91"	50			
10'	72" x 96"	115"	108"	55			
11'	78" x 104"	124 1/4"	116"	65			
150"	87" x 116"	136 1/4"	129 1/2"	78			
15'	108" x 144"	165 3/4"	158"	90			
HDTV Format (16:9)							
65"	31 3/4" x 56 1/2"	72 1/2"	65 1/2"	34			
73"	36" x 64"	80"	73"	36			
82"	40 1/2" x 72"	89"	82"	38			
92"	45" x 80"	97 1/2"	90"	50			
106"	52" x 92"	110"	104"	58			
119"	58" x 104"	122"	115"	65			
133"	65" x 116"	135"	127"	75			
161"	79" x 140"	160 1/4"	152"	80			



*Additional drop will increase overall case length and dowel length. Case may be recessed mounted. Dowel clearance for recessed mounting equals dowel length plus 1".