

AVID And SONY NXCAM



USING SONY NXCAM ON AVID EDITING SYSTEMS

©Paul Sampson, June 2011

With reviews and assistance from Bob Russo (Avid), Chris da Costa, François Gauthier (Sony)

Based on Avid Media Composer 5.5 / Symphony 5.5 / Newscutter 9.5

EDIT VIA:

AMA

QT AMA

IMPORT

Select a bin and choose FILE > IMPORT.

On import the file is converted (Transcoded) into the format you select in the IMPORT dialogue. Choose a standard Avid format for editing speed and efficiency (Avid compression such as 2:1 for SD, or DNxHD codecs for HD) or a more specialized codec for compatibility with your server or other footage (MPEG 30, XDCAM 50, etc)

Import time can be several times longer than realtime. The import (transcode) efficiency is CPU dependant so times will vary. You might consider importing only what you need, not all your footage if you are in a hurry.

RECORDED FILE STRUCTURE

MTS files are AVC HD Video files.

MPG Files are the SD recordings, if present. The SD files are not supported in Avid products.

This structure contains some hidden items. Ensure SHOW HIDDEN FILES is ON before copying contents off the record medium manually. You may want to perform copies with the Sony CMU (Content Management Utility) discussed later.

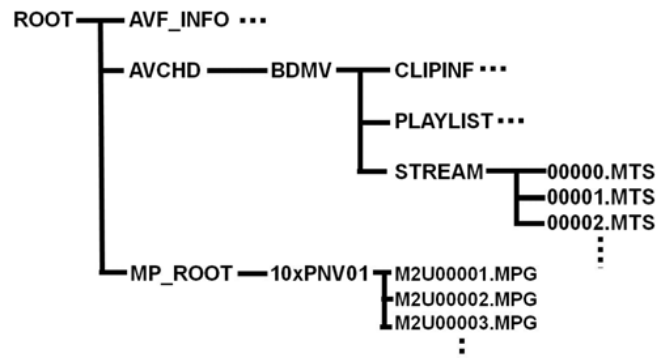

RECORD MEDIUM:

Depending on the camera model used for acquisition:

- Internal camera memory
- Memory Stick PRO Duo(Mark2)[™] media
- Memory Stick PRO-HG Duo[™] media
- Memory Stick PRO-HG Duo HX[™] media
- SD/SDHC Memory Card
- Flash Memory Unit (Sony HXR-FMU128)

Transfers are often done directly off the camera unit itself, especially on the lower end models where there is a lot of internal memory and many hours of recording internally is possible.

FILE FORMAT:

NXCAM is AVCHD (**A**dvanced **V**ideo **C**oding **H**igh **D**efinition) video. It is a Sony and Panasonic file based codec only – there are no AVCHD tapes. The HD files are of type **.MTS**, designed to use half the bitrate of MPEG 2 codecs of similar quality. Recordings could arrive at your door as 1080i, 1080p or 720p at various frame rates. The SD files are **.MPG** - MPEG-4 AVC/H.264. Avid editing systems will **not** import the SD video from these cameras!

H264 is the same base format as Blu-ray discs and some internet streaming. The file structure is like a Blu-ray disc. A typical path to the HD media would be:

PRIVATE > AVCHD > BDMV > STREAM > (MTS FILES HERE)

The recording root directory contains a hidden file AVF_INFO. When making an archival copy of your recording medium to a hard drive, ensure SHOW HIDDEN FILES is ON before you make the copy so you copy all files.

MTS files in this format will not exceed 2 GB. Long recordings will automatically span multiple files. If you have a long recording (exceeding about 10 minutes using AVCHD FX 24Mbps 1920x1080/60i), you may need to import and edit together multiple files to recreate the full recording. Alternatively, use the Sony software “CMU” to copy and join spanned clips into a single file. More on Sony Content Management Utility later.

PRODUCTION SUPPORT: WINDOWS SCREENING

Windows 7 is able to import and play AVCHD video natively; having files with extensions M2TS, MTS and M2T pre-registered in the system. Windows 7 does not support importing of AVCHD video metadata such as thumbnail images, playlists, and clip index files. Windows Explorer is able to create thumbnails for each clip.

ffdshow is an Open Source collection of codecs, including an AVCHD decoder. It is available from <http://sourceforge.net/projects/ffdshow-tryout/> It is free.

CoreAVC is an H.264 decoder for Windows, which can decode AVCHD and a variety of other H.264 formats. It is available for about \$10 at <http://corecodec.com/products/coreavc/>

PRODUCTION SUPPORT: SONY CMU

SONY CMU (Content Management Utility) is a Windows software application for transferring to local hard drive storage, and for previewing the recordings either on the camera or the copy on the hard drive. It is useful to screen recorded contents to choose what media to import. While at its simplest you might just import the MTS files you need to the Avid, you could also use a workflow where you use the CMU to:

- Transfer clips from camera or a memory card to local hard disc storage via the CMU.
- Use the CMU to browse and select the necessary clips.
- Import the selected clips to the NLE project bin.
- Begin editing.

CMU changes the file extension to **.m2ts** when making copies. It will also join any recordings which contain spanned 2GB clips into a single file of the type **.m2ts**.

This software is available from the Sony NXCAM Micro Site (see below) and **requires a connected NXCAM device to install!**

REFERENCES:

Sony Microsite	http://pro.sony.com/bbsc/ssr/micro-nxcamsite/
AVCHD Organization	http://www.avchd-info.org/
VIMIO Samples Site	http://vimeo.com/groups/nxcam
Wikipedia	http://en.wikipedia.org/wiki/AVCHD#NXCAM

FORMATS:

HD (AVCHD)

Video Compression

- **FX mode** (1920x1080 or 1280x720, 21 Mbps*)
- **FH mode** (1920x1080 or 1280x720, 16 Mbps)
- **HQ mode** (1440x1080 or 1280x720, 9 Mbps)
- **LP mode** (1440x1080 or 1280x720, 5 Mbps)

*Including audio and ancillary data the total data rate is 24Mbps

Frame Rate, 60i models

- 1080/60i (59.94i)
- 1080/30p (29.97p)
- 1080/24p (23.98p)
- 720/60p (59.94p)

Frame Rate, 50i models

- 1080/50i
- 1080/25p
- 720/50p

Audio

- Linear PCM (uncompressed)
- AC-3 (compressed)

SD (MPEG2)

The SD Video will not import into Avid Editing Systems.

Video Compression

- MPEG2 Program Stream, approx. 9Mbps
- NTSC (720x480) or PAL (720x576)
- 4:3 or 16:9 selectable

Frame Rate, 60i models

- 480/60i (59.94i)
- 480/30p scan: 30p is recorded as 60i
- 480/24p scan: 24p is recorded as 60i with 2-3 pulldown.

Frame Rate, 50i models

- 576/50i
- 576/25p scan: 25p is recorded as 50i

Audio

- AC-3 only

SONY NXCAM RECORDERS

All NXCAM products come from Sony, and the current models are indicated below. Price ranges for these products is indicated by the number of asterisks. Prices range from under \$2000 USD (*) to over \$5000 USD (***). Cameras are shown below with the Sony one paragraph description followed by some other pertinent information. All cameras offer a USB connection to your computer.



NEX-FS100UK ***

The NEX-FS100UK is an interchangeable lens camcorder featuring a Super 35mm sensor equivalent in size to Super35mm film like that used in the PMW-F3. Developed specifically as a digital motion camcorder it is capable of producing footage with shallow depth of field similar to that of a film camera and capture with high image fidelity

HDMI, Component and Composite Video
Slow and Quick Motion (Over & Under Cranking)



HXR-NX5U **

The new HXR-NX5U camcorder is the first product of the Sony NXCAM generation, and a new category of tapeless memory camcorder, providing an ideal balance of power and performance in the digital age. Utilizing the revolutionary AVCHD format, this camcorder offers long duration recording - with dual memory slots - on affordable consumer memory cards. As it facilitates a totally IT-based workflow, the HXR-NX5U has the potential to profoundly change the way content is created. Simultaneous hybrid recording is available in HD and SD formats, using the optional HXR-FMU128 flash memory unit. In any format, breathtaking picture quality is assured with proven features such as a state-of-the-art G Lens and three Exmor CMOS sensors with a ClearVid array. Professionals expect this standard of picture quality from Sony ... and accept nothing less.

Memory Stick PRO DUO and SD/SDHC
HD-SDI, SD-SDI, HDMI Video, Composite, Component Video
OUT



HXR-NX70 **

From its G-Lens through the CODEC, the HXR-NX70 is a true NXCAM camcorder with the added bonus of IPX54 certification. Its compact size and XLR pod, coupled to NXCAM quality and performance makes it ideal for a wide range of applications.

Rain and Dust resistant

Memory Stick PRO DUO and SD/SDHC, **Internal Memory 96GB**

HDMI Video, Composite, Component Video



HXR-MC2000U *

The HXR-MC2000U is a professional, shoulder mount AVCHD camcorder. This camera is ideally suited for customers stepping up to file based workflow. It records high-def. AVCHD or DVD quality MPEG-2 standard-def. onto its built-in 64GB solid state drive or to readily available, consumer memory cards. With premium design characteristics and full-raster high-definition 1080i recording capability, the HXR-MC2000U is ideal for weddings, corporate communications, colleges, universities, sporting events, and working videographers on a budget.

Internal 64GB HDD

SD/SDHC/SDXC media cards, Memory Stick Duo™

HDMI Video, Composite, Component Video



HXR-MC50U *

The HXR-MC50U is an ultra-compact, professional, AVCHD camcorder with big camera performance. With premium design characteristics such as wide-angle Sony G lens, single 1/2.88-inch size Exmor™ R sensor with six million pixels, adaptive MPEG-4 codec, full-raster 1920 x 1080i recording capability, the HXR-MC50U is ideal for multimedia journalists, documentarians, indie filmmakers and any other application where a small, high quality camera is required.

Small camera with Infrared Night Vision

HDMI Video, Composite, Component Video

Internal 64GB HDD

SD/SDHC/SDXC media cards, Memory Stick Duo™